

PART NO.	UVB STABILIZED	BUNDLE DIA. MIN	BUNDLE DIA. MAX	"L" LENGTH APPROX	"W" WIDTH REF	"T" THICKNESS REF	"A"	"B"	"C"	MIN LOOP TENSILE	FIGURE NO.
WIT-RT-0550	STANDARD	3/16 [4.8]	1-1/4 [31.8]	5-1/2 [139.7]	.21 [5.3]	.05 [1.3]	.24 [6.1]	.36 [9.1]	.45 [11.4]	40 lbf (18 kgf)	1
WIT-RT-0800			2 [50.8]	8 [203.2]							
WIT-RT-1050			2-1/2 [63.5]	10-1/2 [266.7]							
WIT-RT-1525	SPECIAL ORDER ONLY	2 [50.8]	4 [101.6]	15-1/4 [387.4]	.52 [13.2]	.09 [2.3]	.38 [9.7]	.80 [20.3]	.86 [21.8]	250 lbf (113 kgf)	
WIT-RT-2150			6 [152.4]	21-1/2 [246.1]							
WIT-RT-2775			8 [203.2]	27-3/4 [704.9]							
*WIT-RT-1			1/4 [6.4]	1-7/8 [48]							8-3/32 [206]

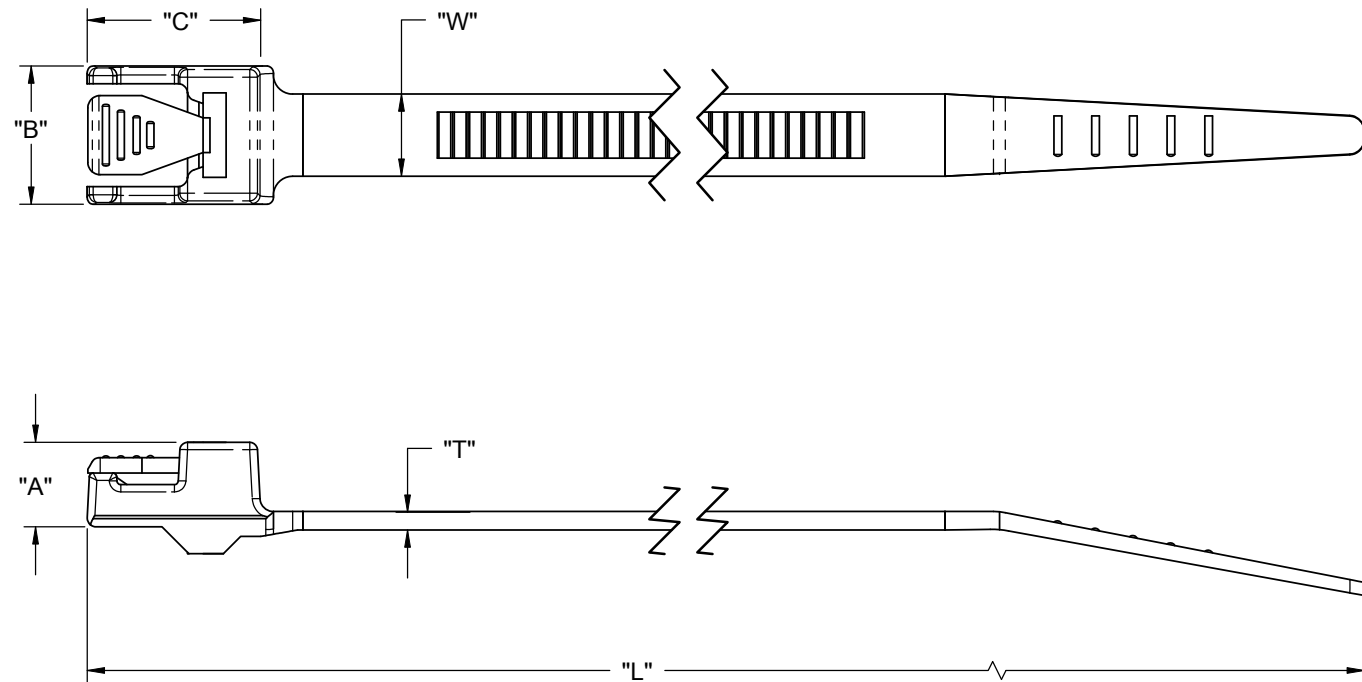

FIG 1.

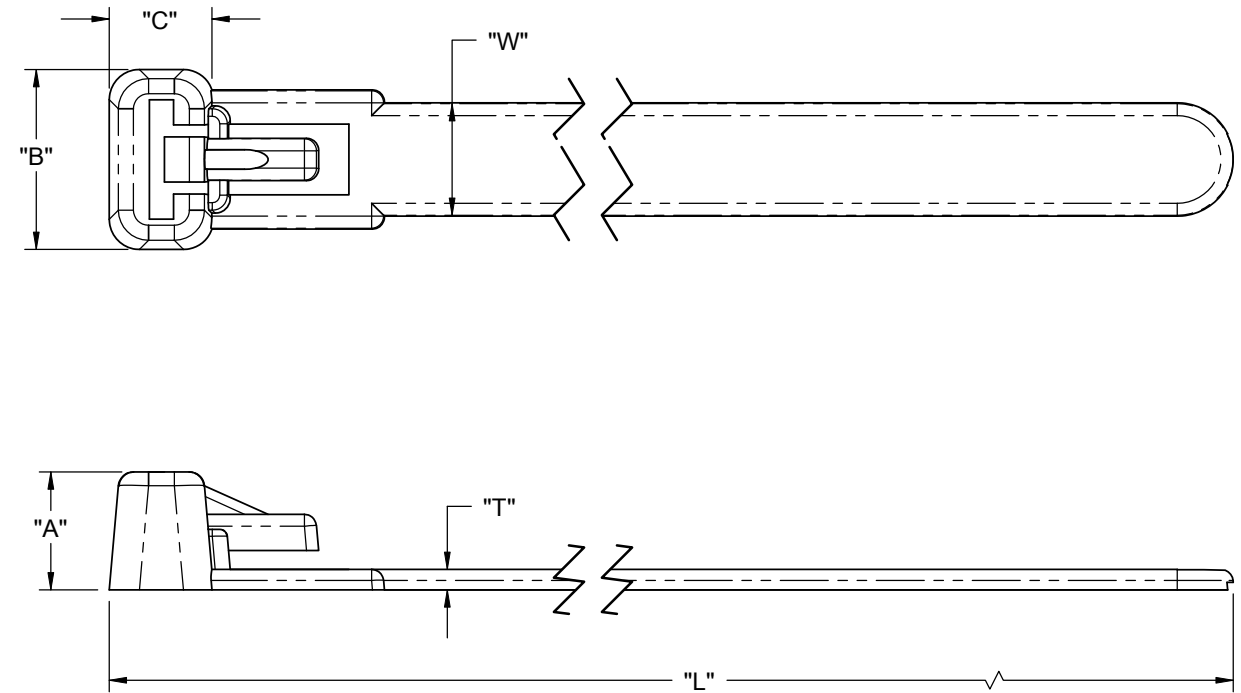

FIG 2.

NOTES:

1. MATERIAL: NYLON 6/6 UL 94 V-2 (RMS-01). COLOR NATURAL.
*COLOR BLACK, BY SPECIAL ORDER ONLY(-BK).

UV STABILIZED NYLON 6/6 (RMS-46), COLOR BLACK.
TO ORDER USE P/N: WIT-RT-XXXX-UVB

2. COLORS: GREEN (-GN), BLUE (-BL), YELLOW (-YL) AND RED (-RD)
AVAILABLE BY SPECIAL ORDER ONLY.
TO ORDER ADD COLOR SUFFIX TO PART NO.

REV.	DESCRIPTION	ENGR.	DATE
A	REDRAWN, SEE CO 200081 FOR CHANGES	SK	12/05/07

TITLE: RELEASE TAB WRAP IT TIES				DWG IN [MM]		FINAL	
CREATED USING SOLIDWORKS	FILE #: WIT-RT	DWN: SK	APP: D.Z.	PART #			
TOLERANCES UNLESS NOTED .XX=±.010 .XXX=±.005 FRAC.=±1/64 ANG.=±1°	SHEET: 1 OF 1 SHEET SIZE: B	DT: 12/04/07	CHKD: S.J.	SEE TABLE		PRINT TYPE	
RE: RICHCO, INC.		RICHCO, INC. ENG@RICHCO-INC.COM (773) 539-4060		CA			